

VORTEX 1000i

HIGH-VOLUME PURIFICATION DEVICE



PRODUCT DESCRIPTION

The AirBox Vortex 1000i HVP is a high-volume air purification unit (APU) designed for HVAC integrated installations for large commercial and industrial environments to provide Equivalent Clean Airflow (V_{ACS}). It delivers powerful airflow with an efficient 4-Stage Filtration composition, inclusive of proprietary adsorbent media, and is equipped with an Advanced Operating System for smart monitoring and control. Built for continuous operation, this air cleaner supports indoor air quality strategies and energy savings with ASHRAE Standard 62.1-2022 Indoor Air Quality Procedure (IAQP) in high-demand spaces.

COMPLIANCE AND PERFORMANCE SPECIFICATIONS

ASHRAE 62.1-2019/2022 IAQP	Compliant
ASHRAE 241-2023	Compliant
IEST-RP-CC007	Certified 99.99% @ 0.3 microns HEPA Filter
US DOE-STD-3020-2015	
UL900	
ISO 16890-1	
Efficacy and Performance Testing	
ASHRAE 52.2-2017	Available upon Request
ASHRAE 145.2-2016	Available upon Request

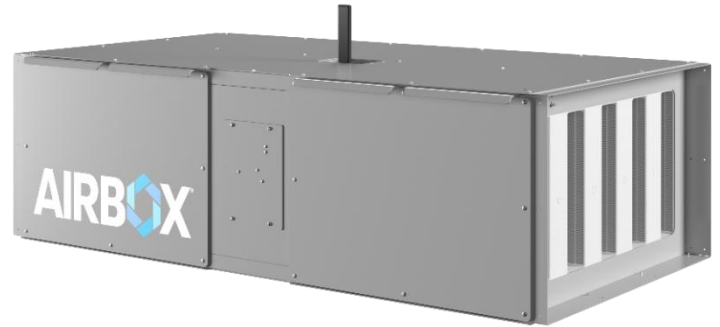

Vortex 1000i HVP

TECHNICAL SPECIFICATIONS

Unit Size	14" H x 24.75" W x 46" L
Weight	145 lbs
Maximum Nominal Air Flow Rate	1,000 CFM
Controls	Standard manual control and UL Listed AirBox Advanced Operating System (IOT) allowing for remote adjustment and BACnet integration. <i>See AOS Spec Sheet for more information</i>
Enclosure Material and Finish	Aircraft Grade Aluminum Alloy Outside Skin with Structural Steel Frame Powder Coat Finish
Duct Sizes	Recommended 12" x 16" Rectangular Duct
External Static Pressure Drop	Up to 1.5" WC
Additional Features	Differential Pressure, Formaldehyde, TVOC, PM2.5, and CO2 sensors for concentration and filter life monitoring.
Warranty	Transferable Limited Lifetime Warranty. Lifetime Warranty on material and workmanship. 5 Year warranty on fan and motor package inclusive of electrical.

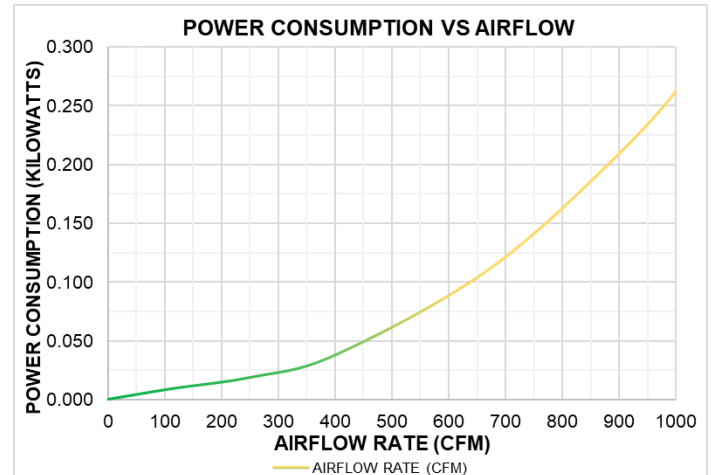

ELECTRICAL SPECIFICATIONS

Operating Voltage	110/120 VAC
Maximum Power	375 W
Maximum Current	4.5 A
ECM Fan	2x 110/120 VAC, 50/60HZ, Ball Bearing, IP54 Rated UL Listed: File Number E46810
Connectors	Deutsch DT, IP68 Rated

FILTRATION SPECIFICATIONS

First Stage	Dual Stage Pre-Filter
	MERV 9 2" Radial Pleated Polyester Filters
Second Stage	MolecuCore Filter
	Filters with Proprietary Blend of High-Flow Adsorbent Media
Third Stage	Dual Stage Pre-Filter
	MERV 9 2" Radial Pleated Polyester
Fourth Stage	HEPA Filter
	Certified 99.99% Effective 12" Pleated Glass Media

BACNET SPECIFICATIONS

Communication Protocol	MS/TP
Hardwire Connection Point	RS485 Port
Total Number of Objects Supported	20 (See AOS Spec Sheet)

**AIRBOX is regulated by the US Environmental Protection Agency and state governments as a pesticidal device. Accordingly, our air cleaners are packaged and labeled in accordance with EPA regulations under FIFRA section 2(q)(1) and 40 CFR Part 156.
EPA Registered Establishment No.: 97081-NC-1**

VORTEX 1000i

HIGH-VOLUME PURIFICATION DEVICE



VORTEX 1000i CLEARANCE VIEWS

